



DESCO TECHNICAL BULLETIN TB-3058

Dual Operator Continuous Monitor Installation, Operation and Maintenance



Made in the
United States of America



Figure 1. Desco Dual Operator Continuous Monitor with Satellites

Description

Leading companies use continuous monitors as a cost effective component in satisfying the section 6.1.3 Compliance Verification Plan requirements of ANSI/ESD S20.20. The Desco Dual Operator Continuous Monitor with Satellites continuously monitors the grounding integrity of two operators, and two ESD worksurfaces' path to ground. The monitor will provide instantaneous notification of static control equipment failures, and eliminates the need of costly and difficult to supervise wrist strap logging record keeping. This unit is highly cost effective as it is designed to monitor any conventional single-wire wrist strap and ground cord system.

Per ESD Handbook ESD TR20.20 section 5.3.2.4.4 Test Frequency, "Because wrist straps have a finite life, it is important to develop a test frequency that will guarantee integrity of the system. Typical test programs recommend that wrist straps that are used daily should be tested daily. However, if the products that are being produced are of such value that knowledge of a continuous, reliable ground is needed, then continuous monitoring should be considered or even required."

The Desco Dual Operator Continuous Monitor is available in the following models:

Item	Power Adapter Input
19246	120VAC
19247	220VAC

The Dual Operator Continuous Monitor with Satellites is an impedance sensing device designed to monitor body types from a 5th percentile female to a 95th percentile male. This range covers a 5 foot tall 90 pound person to a 6 foot 5 inch 250 pound person in any production environment.* The 19246 is powered by a 120 VAC, 60/50 Hz, plug-in transformer which also provides connection to ground.

No user adjustment required: The Continuous Monitor is drift-free and designed to be insensitive to the effects of squeezing or stretching the coil cord. It requires no user adjustment.

The Dual Operator Workstation Continuous Monitor is a real time instrument that ensures that critical ESD control components in a sensitive area are effectively grounded. It independently monitors the operator and the worksurface. The instant an operators wrist strap or cord fails, the monitor will issue audible and visual alarms alerting the user of the problem. In the same manner, the unit also confirms that a path to ground of less than 10 megohms (1×10^7 ohms) exists from the ESD protective worksurface(s).

ADVANTAGES OF CONTINUOUS MONITORING OVER PERIODIC TESTING

Many customers are eliminating periodic touch testing of wrist straps and are utilizing continuous monitoring to better ensure that their products were manufactured in an ESD protected environment. Full time continuous monitoring is superior to periodic or pulsed testing, and can save a significant amount of money in testing costs and rejected product. Periodic testing detects wrist strap failures after ESD susceptible products have been manufactured. The costs of dealing with the resulting catastrophic failures or latent defects can be considerable. Dual Operator Workstation Continuous Monitors eliminate the need for users to test wrist straps and log the results; by their function, these monitors satisfy the ISO and ANSI/ESD S20.20 test logging. ANSI/ESD S20.20 Paragraph 6.2.2.2 Personnel Grounding Guidance states "A log should be maintained which verifies that personnel have tested their personal grounding devices." Per ESD-S1.1 Paragraph 6.1.3 "Daily (wrist strap system) testing may be omitted if constant monitoring is used."

WAVE DISTORTION DETECTION TECHNOLOGY PROVIDES TRUE 100% CONTINUOUS MONITORING

From the technical alternatives available, Desco designs and manufactures many of its Continuous Monitor product offerings using wave distortion technology. Wave distortion circuitry monitors current/voltage phase shifts and provides true 100% continuous monitoring. Electrical current will lead voltage at various points due to the combinations of resistance and capacitive reactance. By monitoring these "distortions" or phase shifts, the wave distortion Workstation Continuous Monitor will reliably determine if the circuit is complete.

*NASA Publication 1024-Anthropomorphic Source Book Volume 1: "Anthropometry for Designers"

** Per ANSI/ESD S20.20 paragraph 6.0.3. Tailoring "This document, or portions thereof, may not apply to all applications. Tailoring is accomplished by evaluating the applicability of each requirement for the specific application. Upon completion of the evaluation, requirements may be added, modified or deleted. Tailoring decisions, including rationale, shall be documented in the ESD Control Program Plan."



Wave distortion technology can be referred to as "vector impedance monitoring". This description is valid as the wave distortion technology measures the impedance at the monitored banana jack and looks for changes in either the capacitance or resistance of the circuit which includes the wrist strap and its wearer. It uses filtering and time domain sampling to filter out false signals caused by voltage offsets, 60 Hz fields and other electro-magnetic and electrostatic interference.

In normal factory environments, and with persons whose capacitance with respect to ground is within design limits (5 feet tall 90 pound person to 6 foot 5 inch 250 pound person), the Dual Operator Workstation Continuous Monitor cannot be "fooled". It will provide a reliable alarm only when the wrist strap or work surface becomes dysfunctional or unsafe according to accepted industry standards. The Dual Operator Workstation Continuous Monitor is drift-free and designed to be insensitive to the effects of squeezing or stretching the coil cord.

ADVANTAGES OF WAVE DISTORTION AND SINGLE-WIRE TECHNOLOGY

The Desco Dual Operator Workstation Continuous Monitor allows the use of any standard, single-wire wrist strap and coil cord. The monitor/wrist strap/cord system life-cycle costs are by far lower than alternative systems which require more expensive & less durable dual-wire cords and special wrist straps. Dual-wire cords are expensive and are the weak link of the system. They are the most likely component to need replacement. Over a five year period this can make a dual-wire system three times as expensive as a system utilizing single-wire wrist straps and cords.

The dictionary defines constant as uniform and unchanging, and continuous as uninterrupted. Nonetheless, some dual-wire resistance monitors utilize a pulsed test current and do not really provide continuous monitoring. For example, during each 2.2 second pulse cycle of a leading "constant" resistive monitor, electrical current is pulsed for only 0.2 seconds followed by an unmonitored interval of 2 seconds. This leaves the user/wrist strap unmonitored for over 90% of each cycle. Damaging ESD events can easily occur in the portion of the time in between the pulses. The off period of 2 seconds equals 2 billion nanoseconds, and "it takes only about 25 volts applied for 100 nanoseconds to blow most memories or microprocessor."* The dual-wire system does not meet all industry ESD S6.1 specifications, as the cords do not meet the EOS/ESD Association guidelines for the 1 to 5 pound "breakaway force" requirement for ensuring a reliable path-to-ground and preventing accidental disconnects.

By using the reliable wave distortion technology to determine if the circuit is complete, there are no false alarms. There is no need to adjust or tune the monitor to a specific user or installation. The miniscule amount of electrical current (less than 1 volt coil cord signal) required to generate the waveform has never caused reported skin irritation and is extremely safe for use in voltage sensitive applications such as disk drive manufacturing.

*1981 article by Donald E. Frank - Electrical Overstress Electronic Discharge Symposium Proceedings

Packaging

- 1 Dual Operator Continuous Monitor (Control Unit)
- 2 Satellite Remotes
- 1 Power Adapter, 24VAC
- 2 Mat Monitor Cords (Black), 6'
- 2 Mat Ground Cords (Green and Yellow), 6'
- 2 Satellite Remote Cables, 7'
- 4 Countersink Washers and Screws (#4 x 1/4")
- 6 Mounting Screws (#8 x 3/4")
- 1 Certificate of Calibration

Installation

Remove the monitor and satellites from its packaging. Inspect for any shipping damage. Confirm that the worksurface is 1×10^7 ohms or less and has a conductive layer such as Dual Layer Rubber, Dissipative 3-Layer Vinyl, or Micastat® Dissipative Laminate with conductive buried layers.

The Control Unit for the Dual Operator Continuous Monitor is normally installed under the bench top toward the front edge of a workstation where the LEDs are easily visible. Use the enclosure's flanges to mount the monitor.



Figure 2. Mounting the Control Unit

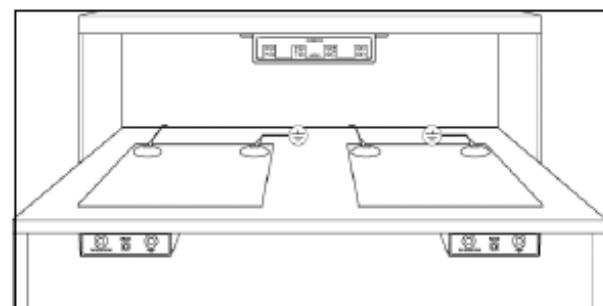

Figure 3. Typical setup of the Dual Operator Continuous Monitor and Satellites



SATELLITE REMOTES

The Satellite Remotes can be installed up to 7 feet away from the monitor control unit. Two operators plus two worksurfaces can be monitored at separate adjacent workstations. The worksurface mat circuit may be bypassed by a switch located at the rear of the satellite. Also shown on each satellite remote is an unmonitored ground connection jack where a supervisor, guest, or equipment can be grounded.



NOTE: Replacement satellites are not available. Satellites cannot be switched between control units. If satellites are damaged or not performing correctly, contact Baskiville for an RMA.

The following procedure will outline how to correctly install the Dual Operator Continuous Monitor and its satellites to properly monitor an ESD protected workstation.

1. Follow the dimensions listed in figures 4 and 5 to properly mount the Dual Operator Monitor's Control Unit and Satellite Remotes.

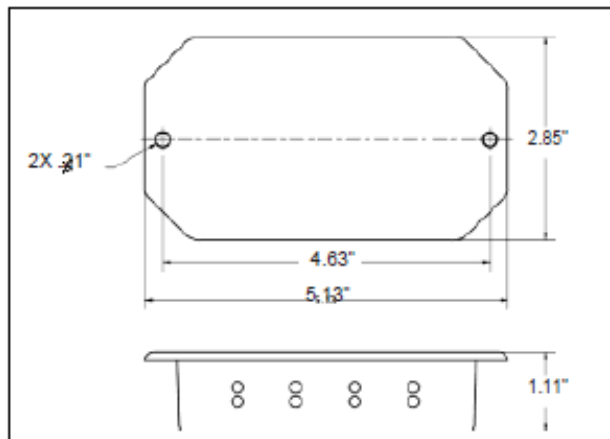

Figure 4. Mounting hole locations of the Control Unit

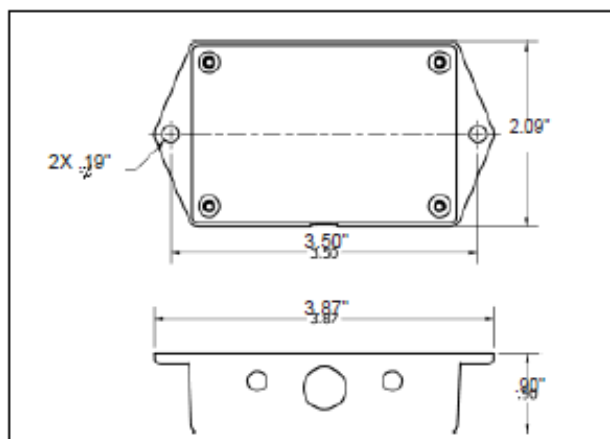

Figure 5. Mounting hole locations of the Satellite Remote

2. Connect the Satellite Remotes to the Control Unit using the included cables.

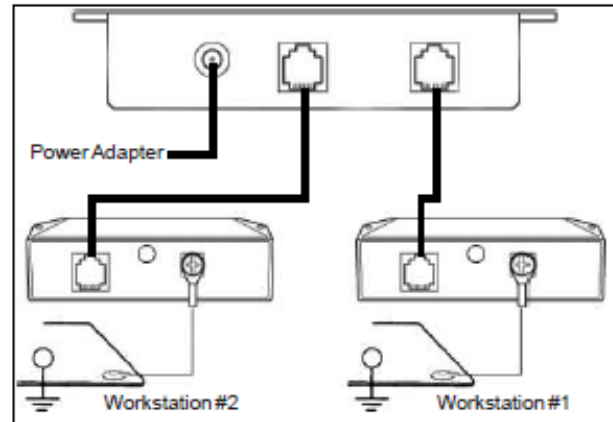

Figure 6. Typical setup of the Dual Operator Continuous Monitor and Satellites

3. Mat monitoring may be bypassed by using the switch located inside the hole located at the rear of the satellite remote.
4. Install Screws and Washers 12 to 72 inches apart from each other on the worksurface mat. Make sure that they pierce and clinch the bottom side of the mat.
5. Ground the worksurfaces by using the included mat ground cords. Snap one end to the worksurface mat and connect the other end to common point ground.
6. Connect the mat ground cord to the remaining worksurface snap. Connect the other end of the cord to the back of the satellite remote.

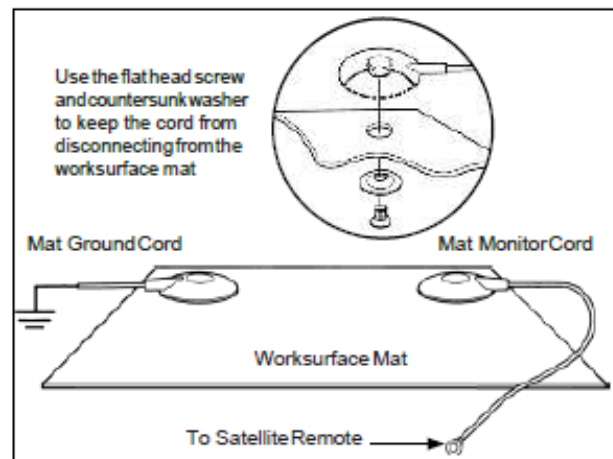

Figure 7. Installing the Mat Ground and Mat Monitor Cords

7. A convenient 3-wire 120 VAC outlet should be located and tested for proper wiring and grounding. We recommend using the Desco 98132 AC Outlet Analyzer to perform these tests.



8. Plug the power adapter into the outlet and connect its plug into the power jack located at the back of the Control Unit. The green worksurface LEDs should illuminate. If the red worksurface LED(s) illuminate and alarm, inspect the snap fastener and ground cords for proper connection. The operator LEDs will illuminate red when an operator is not connected. The Dual Operator Continuous Monitor is now ready for use.

Installation on Micastat® Laminate

Materials Needed:

- 2 Flush Mount Ground Laminate Inserts
- 1 Installation Tool for Flush Mount Insert

1. Install the Flush Mount Inserts first. It is recommended to install one in the right back corner and the other in the left back corner of the Micastat® laminated bench top.
2. Once both inserts are installed, cut the ground cord supplied with the monitor into two pieces; make sure that the tinned end is long enough to connect from the worksurface terminal on the Satellite Remote to one of the flush mount terminals located under the bench.
3. The remaining wire can then be used to connect the other flush mount terminal to ground using the supplied ring terminal. The shrouded molded end can then be cut off.

When complete, one flush mount terminal will connect the Micastat® laminate to ground while the other will connect it to a satellite remote. The satellite remote then monitors the ground connection between the two inserts, and since Micastat® is the only ESD laminate made with a physical uniform ground layer, it will monitor the entire Micastat® surface ground. The wires will stay under the bench, maximizing the usable space on the bench top.

Operation

When the satellite remote unit is installed and connected to a grounded ESD protective worksurface, the monitor's green worksurface LED's and red operator LED's should be illuminated. The monitor takes 6 seconds to activate its audible alarm circuitry when first powered.

To use the monitor:

1. Plug a wrist strap cord, into the jack labeled OPERATOR on the satellite remotes. This automatically activates the selected operator channel. The red operator LED should illuminate, and the buzzer should sound.
2. Remove the charges from your body by making contact with a properly grounded ESD worksurface. Snap the cord to the wristband, which should fit snugly on your wrist. This should silence the alarm and cause the LEDs to switch from red to green. If this does not happen, check the wrist cord for continuity or damage. Examine your wristband and ensure that it has a secure fit. If you have dry skin, use ESD hand lotion such as Menda Reztore® ESD Hand Lotion.

All Desco single-wire monitors with wave distortion technology include the Park Snap feature. Use the Park Snap to store the operator's wrist cord and enable standby mode while the operator is away from the workstation. Before disconnecting the coil cord from the wristband, the operator touches the Park Snap to disable the audio alarm for 6 seconds. Within the 6 second period, the operator can disconnect their wrist cord from their wristband and attach it to the Park Snap before the audible alarm sounds. If the cord is plugged into the OPERATOR jack, the monitor will alarm continuously until the cord is either parked or unplugged.

WORKSURFACE CHANNEL

The Dual Operator Continuous Monitor's worksurface monitoring circuitry is sufficiently sensitive to detect extremely low current, allowing it to be used with mats having a resistance of up to 1×10^7 ohms (10 megohms). If the user desires not to monitor the worksurface, the circuit can be bypassed with the switch located at the rear of the satellite.

When the monitor is connected to a static dissipative worksurface, the amount of current that flows is a function of the total resistance between the monitor and the worksurface to ground. When the resistance of the worksurface is below a present threshold, the monitor will indicate good. Conversely, if the resistance level is high when compared to the monitor's reference, the unit will alarm. This is an integrating resistance measuring circuit. Therefore, it is relatively insensitive to externally induced electromagnetic fields. The resistance threshold is factory set to 10 megohms (1×10^7 ohms).

Custom worksurface range is available upon request. Contact customer service for more details.

Note: Per ESD S6.1, Grounding paragraph 4.1.1 "Every element to be grounded at an ESD protected station shall be connected to the same common point ground." The ESD control plan should include a tailoring** statement that continuous monitors are used and that consistent with manufacturer's design grounding is via AC adapter cord to equipment ground.



Calibration

Frequency of recalibration should be based on the critical nature of those ESD sensitive items handled and the risk of failure for the ESD protective equipment and materials. In general, Desco recommends that calibration be performed annually.

Use the Desco 98221 Wave Distortion Monitor Verification Tester to perform periodic verification (once every 6-12 months) of the Dual Operator Continuous Monitor. The verification tester can be used to check the test limits of the Dual Operator Continuous Monitor without removing it from the workstation.

See TB-3074 for more information.



Figure 8. Desco 98221 Wave Distortion Monitor Verification Tester

Specifications

Input Voltage and Frequency (External Adapter)	AC/DC Power Adapter Power Input: 100-240VAC, 50/60 Hz Power Output: 24VDC @ 150mA Cable Length: 5 ft. (1.5 m)
Operating Temperature	50 to 95°F (10 to 35°C)
Environmental Requirements	Indoor use only at altitudes less than 6500 ft. (2 km) Maximum relative humidity of 80% up to 85°F (30°C) decreasing linearly to 50% @ 85°F (30°C)
Dimensions (Monitor)	5.13" L x 2.85" W x 1.11" H (130 mm x 72 mm x 28 mm)
Dimensions (Satellite Remote)	3.87" L x 2.09" W x .90" H (98 mm x 53 mm x 23 mm)
Weight (Monitor)	0.25 lbs. (0.11 kg)
Weight (Satellite Remote)	0.14 lbs. (0.06 kg)
Operator Test Range*	500 kilohms to 10 megohms impedance
Worksurface Test Limit**	10 megohms (±10%)
Operator Test Voltage	1.2V peak-to-peak @ 1.2µA, open circuit
Worksurface Test Voltage	5 to 7.5V, open circuit
Alarm Response Time	<50 ms
Country of Origin	United States of America

*This cannot be verified with standard DC test equipment. The continuous monitor is an impedance sensing device, and the limits are determined by the magnitude and angle of the impedance.

**The worksurface mat must have a conductive layer such as Dual Layer Rubber or Dissipative 3-Layer Vinyl with conductive buried layers. Desco workstation monitors are not recommended for use with homogeneous matting.